



®

ES330Q-Z

SPLIT SYSTEM AIR-COOLED 32 HP DUAL-CIRCUIT TANDEM SCROLL

DIMENSIONAL DRAWINGS

EVAPORATOR SECTION - ES330Q

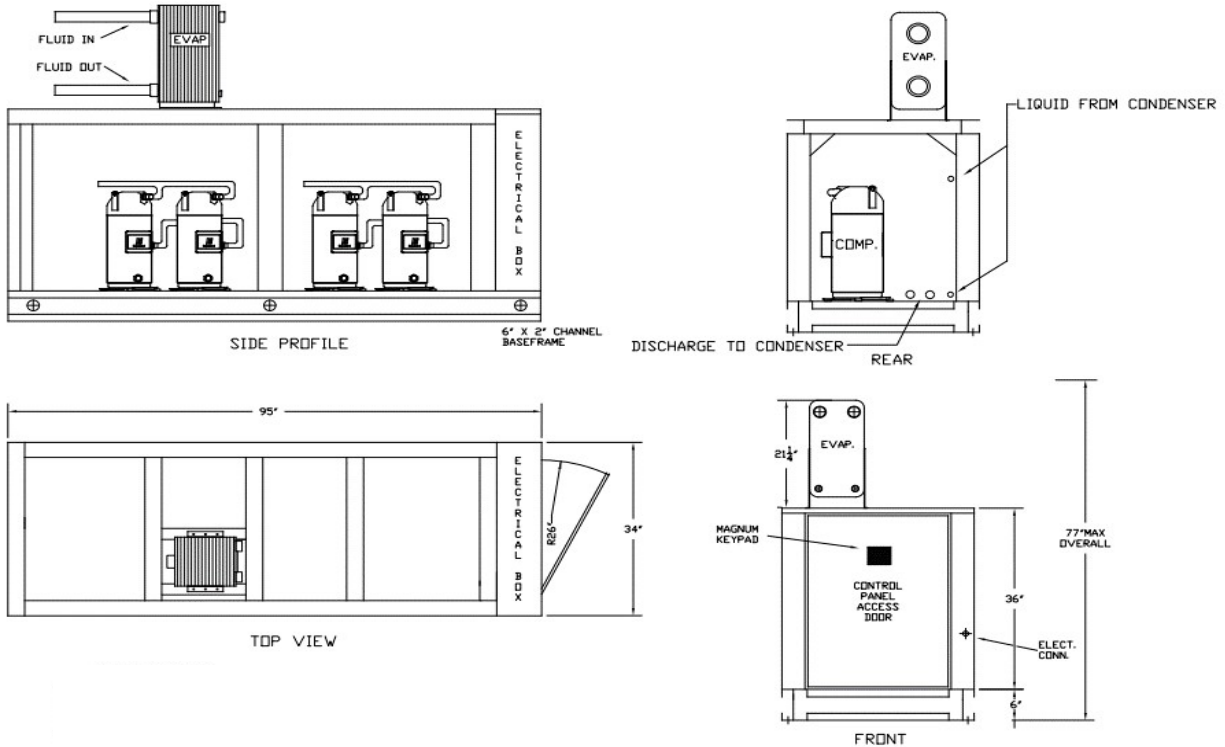

LENGTH	WIDTH	HEIGHT	WEIGHT	FLUID CONNECTIONS	R407C CONNECTIONS	
					DISCHG	LIQUID
95"	34"	77"MAX	1600 LB	2" F-NPT	1-1/8"	7/8"

PRODUCT PERFORMANCE INFORMATION

REFRIGERANT	COMPRESSOR OPER. SUCTION TEMP. RANGE	LFT °F	70 °F AMB		85 °F AMB		95 °F AMB		100 °F AMB		105 °F AMB	
			TONS	KBTU/H	TONS	KBTU/H	TONS	KBTU/H	TONS	KBTU/H	TONS	KBTU/H
R407C	10°F to 55°F	20	18.1	217	16.4	196	14.9	179	14.1	170	13.3	159
		35	25.6	307	23.7	284	22.1	265	21.2	255	20.3	243
		45	31.7	381	29.6	355	27.8	334	26.9	322	25.8	310
		55	38.9	467	36.4	437	34.5	414	33.4	401	32.3	387
		60	42.9	515	40.3	483	38.2	458	37.1	445	35.9	430

DRAKE REFRIGERATION INC
 2900 SAMUEL DRIVE
 BENSLEM, PA 19020
 (888) 289-7299
www.drakechillers.com

*ALL INFORMATION **FOR REFERENCE ONLY**



®

ES330Q-Z

SPLIT SYSTEM AIR-COOLED 32 HP DUAL CIRCUIT TANDEM SCROLL

DIMENSIONAL DRAWINGS

CONDENSER SECTION - CS330Q

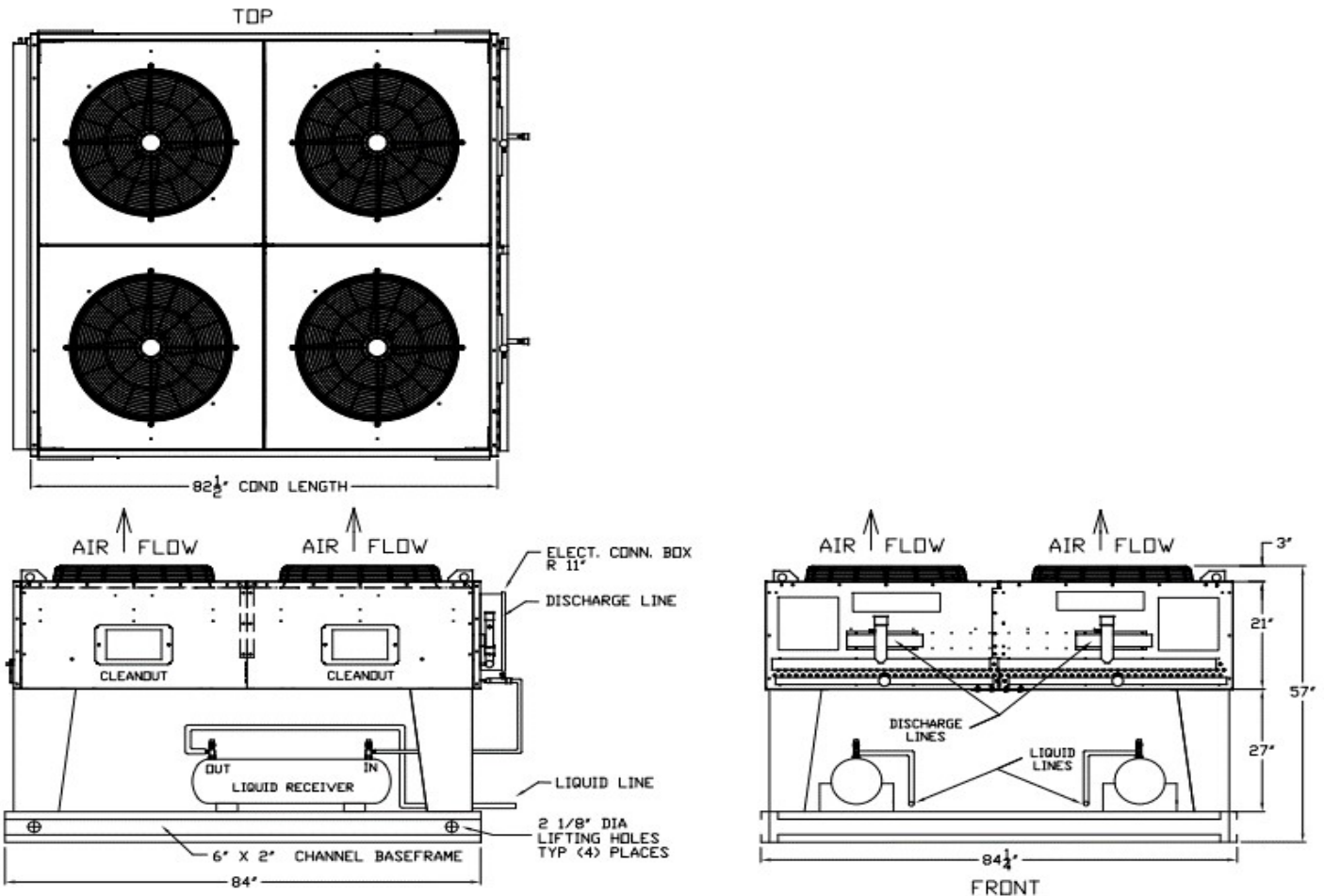

LENGTH	WIDTH	HEIGHT	WEIGHT	R407C CONNECTIONS	
				DISCHG	LIQUID
90" MAX	84.25"	57"	1450 LBS	1-1/8"	7/8"

DRAKE REFRIGERATION INC

2900 SAMUEL DRIVE
 BENSLEM, PA 19020
 (888) 289-7299

www.drakechillers.com

*ALL INFORMATION *FOR REFERENCE ONLY*



ES330Q-Z

SPLIT SYSTEM AIR-COOLED 32 HP DUAL-CIRCUIT TANDEM SCROLL

STANDARD FEATURES

FEATURE	BENEFIT
Listings	ETL 3046941, UL STD 1995, CAN/CSA STD, C22.2 No. 236
Micro Control Systems Controller	Open source, microprocessor built to operate in the HVAC/R industry
Controls	BMS, BAS communications, remote access, monitoring services
Stainless Steel Brazed Plate Evaporator	Corrosion resistant, fully insulated and selected upon requirements
Copeland Tandem Scroll Compressors	Industry leader, long lasting compressor
25%-100% Capacity Control	Allows for tight control on varying loads
Compressor Crankcase Heater	Prevents compressor damage caused by cold refrigerant on startup
Suction Accumulator	Protects the compressor from damage caused by liquid flood back by preventing liquid from entering the compressor
Water Flow Switch	Protects against process fluid freezing caused by pump failure
Hot Gas Bypass	Aids in the prevention of evaporator freeze ups and capacity control
Copper Tube/Aluminum Fin Condenser	Rust resistant and high CFM
Compressor Vibration Eliminators	Eliminates vibration transfer and reduces noise
Painted Galvanized Steel Metal Cabinet	Sturdy, corrosion resistance, professional appearance
Insulated Process Fluid Lines	Maximum thermal efficiency
Factory Tested	Ensures the unit meets the customer's performance designed criteria and arrives in working order
Full Refrigerant Charge	Hassle free and more efficient installation
NEMA 3R Rated Electrical	Indoor/outdoor use
Phase Monitors	Electrical protection for compressors

AVAILABLE OPTIONS

OPTIONS	AVAILABLE
Extended Warranty	4 year extended compressor warranty
Electronic Expansion Valves	Added consistency, efficiency, and control
Electrical	Compressor fusing, disconnects, circuit breakers and more
Stainless Steel Pumps	1/3 HP to 25 HP on board pumps in multiple configurations & options
Fluid Piping Upgrades	Flow meters, pressure gauges, low flow bypass valves, and more
Chiller Evaporator Barrel	Enhanced corrosion resistance and cleanable, fully insulated, extra capacity
Coastal Protection/Hazardous Environments	Heresite coating, "Gold" and Copper condenser coils
Low Ambient Protection	EC fan for temperature down to +10°F, Head pressure control for temperatures down to 20°F, Heated receivers for temperature down to -40°F
Other	Service outlets, city water add-ons, heaters, etc.

More options and customization available, contact factory for information: (888) 289 - 7299

AVAILABLE MODEL NUMBER VOLTAGE REFERENCE

T3 (208-230/3/60) --- T4 (460/3/60) --- T5 (575/3/60)

PRODUCT INFORMATION

MODELS AVAILABLE	COMPRESSOR			RLA EA	LRA EA	FAN MOTOR		MCA	MOP	RECIRC. TANK
	MODEL	QTY	HP			QTY	FLA EA			
R407C										
ES330Q3-T3-Z	ZR94KCE	4	8 EA	32.1	195	4	2.3	150	175	N/A
ES330Q3-T4-Z				16.4	95		1.2	70	85	
ES330Q3-T5-Z				12	80		0.9	55	60	

DRAKE REFRIGERATION INC
 2900 SAMUEL DRIVE
 BENSALEM, PA 19020
 (888) 289-7299
www.drakechillers.com

*ALL INFORMATION **FOR REFERENCE ONLY**