

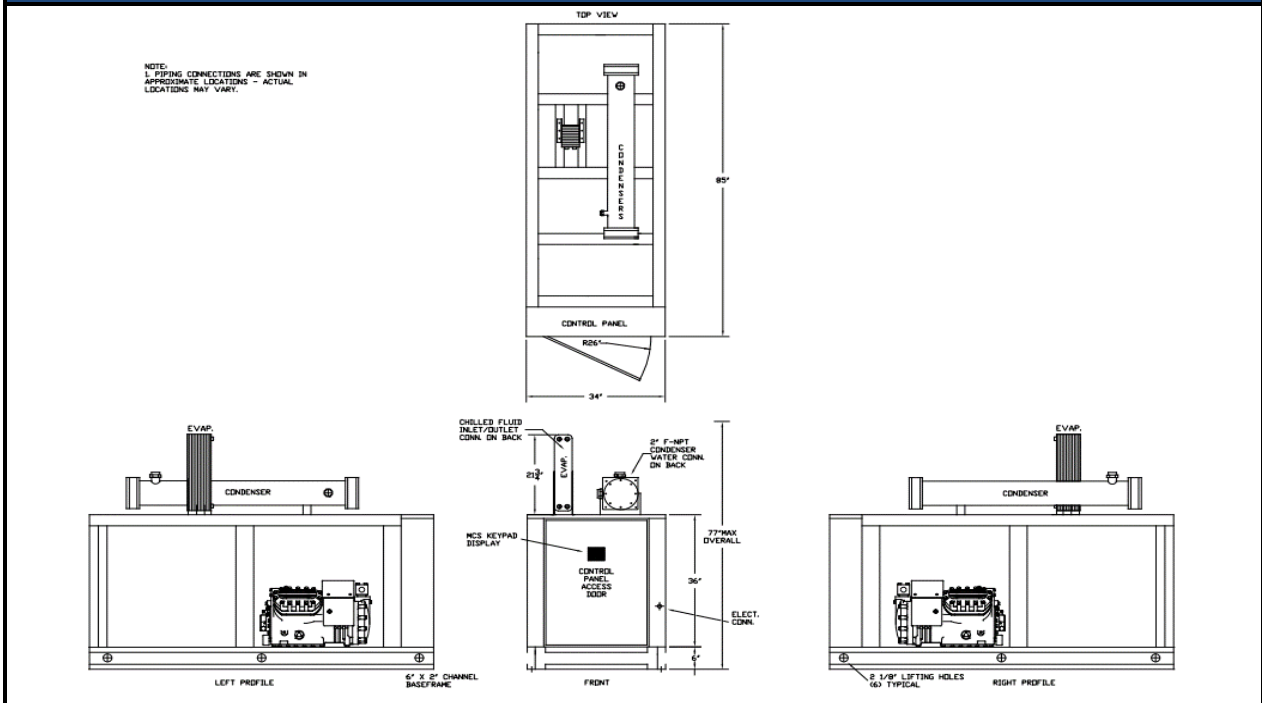

PWC500S-S

PACKAGED WATER-COOLED 50 HP SINGLE CIRCUIT SEMI-HERMETIC

DIMENSIONAL DRAWINGS



LENGTH	WIDTH	HEIGHT	WEIGHT	FLUID CONNECTIONS
85"	34"	77" MAX	1950 LBS	3" F-NPT

PRODUCT PERFORMANCE INFORMATION

REFRIGERANT	COMPRESSOR OPER. TEMP. SUCTION RANGE	LFT °F	70°F COND		90°F COND		105°F COND		120°F COND	
			TONS	EER	TONS	EER	TONS	EER	TONS	EER
R407C	10°F to 50°F	20	28.4	12.8	24.7	9.7	22.0	8.0	19.2	6.5
		30	36.0	15.6	31.5	11.6	28.2	9.4	24.8	7.6
		40	45.1	18.9	39.6	13.8	35.5	11.0	31.5	8.8
		50	55.8	23.1	49.2	16.5	44.3	13.0	39.3	10.2
		60	N/A	N/A	60.5	19.7	54.6	15.3	48.6	11.9
R404A	-10°F to 45°F	0	22.2	9.8	18.7	7.6	16.1	6.2	13.5	5.0
		10	28.3	11.4	23.9	8.7	20.8	7.1	17.5	5.7
		25	39.9	14.5	34.1	10.7	29.7	8.5	25.3	6.7
		40	54.5	18.4	46.7	13.8	40.8	10.3	34.9	8.0
		50	N/A	N/A	56.9	15.3	49.8	11.7	42.5	9.0
		55	N/A	N/A	62.6	16.5	54.7	12.6	46.8	9.5

DRAKE REFRIGERATION INC
 2900 SAMUEL DRIVE
 BENSALEM, PA 19020
 (888) 289-7299
www.drakechillers.com

*ALL INFORMATION **FOR REFERENCE ONLY**



PWC500S-S

PACKAGED WATER-COOLED 50 HP SINGLE CIRCUIT SEMI-HERMETIC

STANDARD FEATURES	
FEATURE	BENEFIT
Listings	ETL 3046941, UL STD 1995, CAN/CSA STD, C22.2 No. 236
Micro Control Systems Controller	Open source, microprocessor built to operate in the HVAC/R industry
Controls	BMS, BAS communications, remote access, monitoring services
Bitzer Semi-Hermetic Compressor	Industry leader, rebuildable, long lasting compressor
Variable Capacity Control	Allows for soft-start and stepped capacity control from 50-100%
Compressor Crankcase Heater	Prevents compressor damage caused by cold refrigerant on startup
Suction Accumulator	Protects the compressor from damage caused by liquid flood back by preventing liquid from entering the compressor
Water Flow Switch	Protects against process fluid freezing caused by pump failure
Hot Gas Bypass	Aids in the prevention of evaporator freeze ups and capacity control
Shell and Tube Condenser	Highly efficient water cooled design
Compressor Vibration Eliminators	Eliminates vibration transfer and reduces noise
Painted Galvanized Steel Metal Cabinet	Sturdy, corrosion resistance, professional appearance
Insulated Process Fluid Lines	Maximum thermal efficiency
Factory Tested	Ensures the unit meets the customer's performance designed criteria and arrives in working order
Full Refrigerant Charge	Hassle free and more efficient installation
NEMA 3R Rated Electrical	Indoor/outdoor use
Phase Monitors	Electrical protection for compressors

AVAILABLE OPTIONS	
OPTIONS	AVAILABLE
Extended Warranty	4 year extended compressor warranty
Compressors	Equivalent compressors available from Copeland and Carlyle
Electrical	Compressor fusing, disconnects, circuit breakers and more
Stainless Steel Pumps	1/3 HP to 25 HP on board pumps in multiple configurations & options
Fluid Piping Upgrades	Flow meters, pressure gauges, low flow bypass valves, and more
Head Pressure Control	Condenser Water Regulating valves
Other	Casters, service outlets, city water add-ons, heaters, water reg. valves etc.

More options and customization available, contact factory for information: (888) 289 - 7299

AVAILABLE MODEL NUMBER VOLTAGE REFERENCE
T3 (208-230/3/60) --- T4 (460/3/60) --- T5 (575/3/60)

PRODUCT INFORMATION											
MODELS AVAILABLE		COMPRESSOR			CONDENSER		RLA EA	LRA EA	MCA	MOP	RECIRC. TANK
R407C	R404A	MODEL	QTY	HP	QTY	CONNECTION					
PWC500S3-T3-S		6FE-50-1Y	1	50	1	3" F-NPT	192.4	950	245	430	N/A
PWC500S3-T4-S							96.2	425	125	215	
PWC500S3-T5-S							77	340	100	170	
PWC500S6-T3-S		6FE-50-1Y	1	50	1	3" F-NPT	192.4	950	245	430	N/A
PWC500S6-T4-S							96.2	425	125	215	
PWC500S6-T5-S							77	340	100	170	

DRAKE REFRIGERATION INC
 2900 SAMUEL DRIVE
 BENSALEM, PA 19020
 (888) 289-7299
www.drakechillers.com

*ALL INFORMATION **FOR REFERENCE ONLY**