



®

VPACT3S

VALUE LINE PACKAGED AIR-COOLED 3.5 HP SINGLE CIRCUIT SCROLL WITH TANK

DIMENSIONAL DRAWINGS

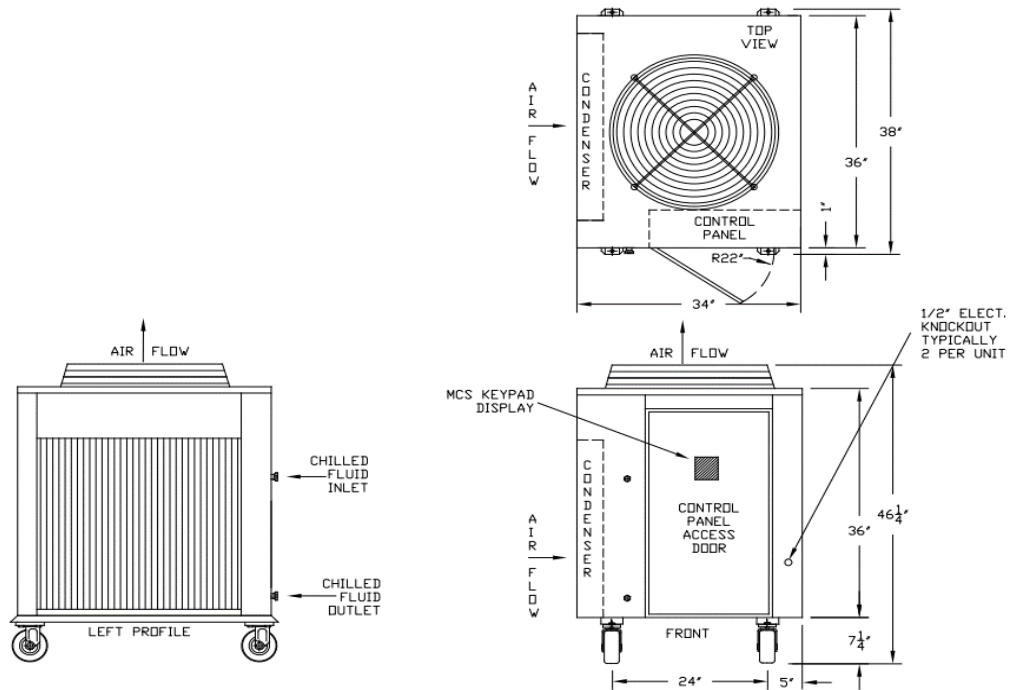

LENGTH	WIDTH	HEIGHT	WEIGHT	TANK CAPACITY	FLUID CONNECTIONS
38"	34"	46.25"	300 LBS	13 GAL.	1" F-NPT

PRODUCT PERFORMANCE INFORMATION

REFRIGERANT	COMPRESSOR OPER. SUCTION TEMP. RANGE	LFT °F	80°F AMB		90°F AMB		95°F AMB		100°F AMB		105°F AMB	
			TONS	EER	TONS	EER	TONS	EER	TONS	EER	TONS	EER
R407C	25°F to 55°F	35	2.3	9.2	2.1	7.7	2.0	7.0	1.9	6.4	1.9	5.9
		45	2.8	11.2	2.7	9.5	2.6	8.8	2.5	8.0	2.4	7.4
		55	3.5	13.5	3.3	11.5	3.2	10.6	3.1	9.7	2.9	9.0
		65	4.2	15.9	4.0	13.7	3.8	12.6	3.7	11.7	3.6	10.7
R404A	-10°F to 45°F	0	1.5	5.4	1.3	4.4	1.2	4.0	1.2	3.5	1.1	3.1
		10	1.8	6.5	1.7	5.4	1.6	4.9	1.5	4.4	1.4	3.9
		25	2.5	8.4	2.3	7.0	2.1	6.4	2.0	5.8	1.9	5.2
		40	3.2	10.4	2.9	8.7	2.8	8.0	2.7	7.3	2.5	6.6
		55	4.0	12.5	3.7	10.6	3.5	9.7	3.4	8.9	3.2	8.1

DRAKE REFRIGERATION INC
 2900 SAMUEL DRIVE
 BENSALEM, PA 19020
 (888) 289-7299
www.drakechillers.com

*ALL INFORMATION **FOR REFERENCE ONLY**



VPACT3S

VALUE LINE PACKAGED AIR-COOLED 3.5 HP SINGLE CIRCUIT SCROLL WITH TANK

STANDARD FEATURES	
FEATURE	BENEFIT
Listings	ETL 3046941, UL STD 1995, CAN/CSA STD, C22.2 No. 236
Micro Control Systems Controller	Open source, microprocessor built to operate in the HVAC/R industry
Controls	BMS, BAS communications, remote access, monitoring services
Stainless Steel Brazed Plate Evaporator	Corrosion resistant, fully insulated and selected upon requirements
Copeland Scroll Compressor	Industry leader, long lasting compressor
Compressor Crankcase Heater	Prevents compressor damage caused by cold refrigerant on startup
Suction Accumulator	Protects the compressor from damage caused by liquid flood back by preventing liquid from entering the compressor
Water Flow Switch	Protects against process fluid freezing caused by pump failure
Hot Gas Bypass	Aids in the prevention of evaporator freeze ups and capacity control
Copper Tube/Aluminum Fin Condenser	Rust resistant and high CFM
Painted Galvanized Steel Metal Cabinet	Sturdy, corrosion resistance, professional appearance
Insulated Process Fluid Lines	Maximum thermal efficiency
Factory Tested	Ensures the unit meets the customer's performance designed criteria and arrives in working order
Full Refrigerant Charge	Hassle free and more efficient installation
Polyethylene Storage Tank	Closed cell insulation for increase temperature control with reliable, corrosion resistant, stainless steel recirculation pump
NEMA 3R Rated Electrical	Indoor/outdoor use
Phase Monitors	Electrical protection for compressors

AVAILABLE OPTIONS	
OPTIONS	AVAILABLE
Extended Warranty	4 year extended compressor warranty
Electrical	Compressor fusing, disconnects, circuit breakers and more
Stainless Steel Pumps	1/3 HP to 25 HP on board pumps in multiple configurations & options
Fluid Piping Upgrades	Flow meters, pressure gauges, low flow bypass valves, and more
Coastal Protection/Hazardous Environments	Heresite coating, "Gold" and Copper condenser coils
Low Ambient Protection	EC fan for temperature down to +10°F
Other	Castors, service outlets, city water add-ons, heaters, etc.

More options and customization available, contact factory for information: (888) 289 - 7299

AVAILABLE MODEL NUMBER VOLTAGE REFERENCE
S2 (208-230/1/60) --- T3 (208-230/3/60) --- T4 (460/3/60) --- T5 (575/3/60)

PRODUCT INFORMATION												
MODELS AVAILABLE		COMPRESSOR			FAN MOTOR		CHILLER PUMP		RLA EA	LRA EA	MCA	MOP
R407C	R404A	MODEL	QTY	HP	QTY	FLA EA	HP	FLA EA				
VPACT3S3-S2-Z		ZB26KCE	1	3.5	1	3.3	1	6.6	20.7	127	40	55
VPACT3S3-T3-Z						3.3		3.7	13.9	88	25	35
VPACT3S3-T4-Z						1.6		1.9	7.1	44	15	15
VPACT3S3-T5-Z						1.9		1.2	5	34	10	10
VPACT3S6-S2-Z		ZB26KCE	1	3.5	1	3.3	1	6.6	23.6	127	40	60
VPACT3S6-T3-Z						3.3		3.7	13.2	88	25	35
VPACT3S6-T4-Z						1.6		1.9	6.4	44	15	15
VPACT3S6-T5-Z						1.9		1.2	5.7	34	15	15

DRAKE REFRIGERATION INC
 2900 SAMUEL DRIVE
 BENSALEM, PA 19020
 (888) 289-7299
www.drakechillers.com

*ALL INFORMATION FOR REFERENCE ONLY